

Magnetic Drilling Machines



With more than 25 years on the Australian Market, The 'Sluggers' brand name has a proven reputation for High Quality, Reliable, Robust and Durable Machines & Cutters. Customers can also be confident with ongoing backup service. Our extensive range of machines, cutters & accessories enable Sluggers products to be used in a diverse range of applications.

FOR A QUICK COMPARISON OF THE FULL RANGE PLEASE VIEW THE MAGNETIC DRILLING MACHINE SELECTION CHART ON PAGE 8

Holemaker 30

Lightweight & Compact, Fully Featured Machine



Featuring a powerful dual coil magnet and 920Watt Industrial motor. The HM30's low profile, integrated coolant system and the ability to quickly change the feed handles to left or right hand operation make this machine ideal for working in confined spaces. Dual rail slide system provides rigidity and eliminates the need for gib adjustments.

*12mm twist drill capacity using Weldon shank twist drill bits.

Optional Accessories & Consumables



Weldon Shank Twist Drills - pg16



Sluggers Cutters - pg12



Holemaker 40

Economical & Versatile Machine



Featuring an 1100watt Motor, Powerful Dual Coil Magnet, Capacity of 40mm Diameter & 52mm Depth of Cut. Available with the option of a Quick Grip arbor for fast tool-less cutter changing, or a conventional grub screw arbor. The ability to easily accept twist drills up to 13mm *using the optional chuck & adaptor, makes this a versatile machine. Through cutter coolant feed, with an external side mounted coolant tank ensures smooth fast clean hole cutting. With all the above features in a high quality, compact, lightweight, durable machine, the Holemaker 40 is Exceptional Value for Money.



Optional Accessories & Consumables



Drill Chuck - pg11



Sluggers Cutters - pg12

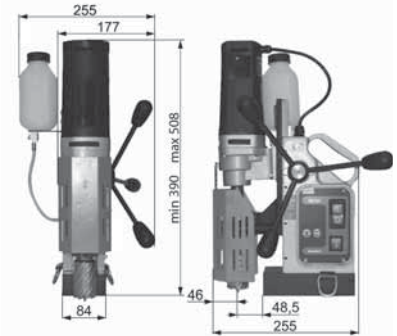

Part Number	HM40 (with Quick Grip arbor) HM40GS (with Grub Screw arbor)
Capacity (Diameter)	40mm
Capacity (Depth)	52mm
Motor Power	1020Watt
Input Power	1100Watt Single Phase 240V
Speed	440rpm
Weight	13.7kg
Magnetic Dead Lift	10650N-m on 25mm Steel Plate
Height (min / max)	390 / 508mm
Incorporated Through Spindle Coolant System	
Smart Magnet Technology to ensure sufficient Magnetic Adhesion	
Supplied In Metal Carry Case with Cutter Guard & Safety Strap	

Holemaker 40 Gear Reduction

With all the features of the Holemaker 40, this unit has the unique feature of Gear Reduction on the down feed which makes for smoother hole cutting & ease of operation. Ideal for drilling harder materials.



Part Number	Description
HM40GR	Holemaker 40 Magnetic Drilling Machine with Gear Reduction on the Downfeed



Part Number	HM30
Capacity (Diameter)	30mm
Capacity (Depth)	52mm
Motor Power	920Watt
Input Power	1010Watt Single Phase 240V
Speed	350rpm
Weight	10.5kg
Magnetic Dead Lift	9500N-m on 25mm Steel Plate
Height (min / max)	306 / 376mm
Incorporated Through Spindle Coolant System	
Smart Magnet Technology to ensure sufficient Magnetic Adhesion	
Supplied In Metal Carry Case with Cutter Guard & Safety Strap	

Magnetic Drilling Machines

FOR A QUICK COMPARISON OF THE FULL RANGE PLEASE VIEW THE MAGNETIC DRILLING MACHINE SELECTION CHART ON PAGE 8



Holemaker 40AD

Low Profile Angle Drive Drilling Machine



A low profile angle drive machine providing a constant working height of 181mm. The HM40AD utilises standard Sluggers Cutters, ensuring a wide range of cutters are always available. The feed handle can be easily changed to either side or removed for use with a socket wrench on the hex drive. Coolant is supplied to the cutter through the spindle by attaching the remote coolant feed bottle.

*12mm twist drill capacity using Weldon shank twist drill bits.



Optional Accessories & Consumables



Weldon Shank Twist Drills - pg16



Sluggers Cutters - pg12

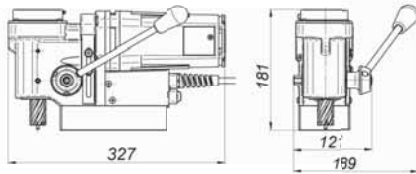

Part Number	HM40AD
Capacity (Diameter)	40mm
Capacity (Depth)	25mm
Motor Power	1020Watt
Input Power	1100Watt Single Phase 240V
Speed	310rpm
Weight	11.1kg
Magnetic Dead Lift	9500N-m on 25mm Steel Plate
Height (min / max)	181mm Constant Working Height
Incorporated Through Spindle Coolant System using remote bottle.	
Supplied In Metal Carry Case.	

Holemaker 50

#2 Morse Taper, Versatile Multi-Purpose Machine



The ability to use Sluggers Cutters, No. 2 Morse Taper Shank Drills & Reamers, as well as a drill chuck makes this a very versatile machine. Satisfying most requirements with a capacity of 52mm Diameter & 52mm Depth of cut when using Sluggers cutters, and 23mm diameter using taper shank drills or reamers. An industrial 2 speed gearbox and 1100w motor provide a strong hardworking machine. Dual rail slide system provides rigidity and eliminates the need for gib adjustments. Handles can be easily changed from left to right hand operation. Top mounted coolant system. Available with the option of a Quick Grip arbor for fast tool-less cutter changing, or a conventional grub screw arbor. Suitable for steel fabrication, engineering workshops & maintenance facilities where a versatile machine is highly beneficial.



Optional Accessories & Consumables



Drill Chuck - pg11



Sluggers Cutters - pg12



Taper Shank Drills pg17

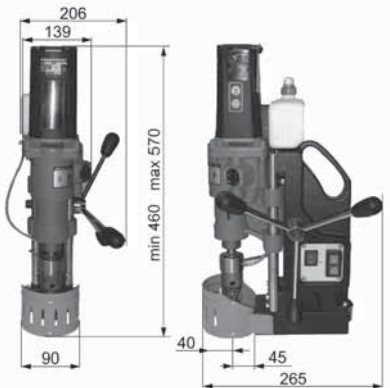

Part Number	HM50 (with Quick Grip arbor) HM50GS (with Grub Screw arbor)
Capacity (Diameter)	52mm
Capacity (Depth)	52mm
Capacity (Twist Drills)	#2 Morse Taper 23mm
Motor Power	1080Watt
Input Power	1200Watt Single Phase 240V
Speed	2 Speed 180 / 360rpm
Weight	16.7kg
Magnetic Dead Lift	11800N-m on 25mm Steel Plate
Height (min / max)	460mm / 570mm
Incorporated Through Spindle Coolant System.	
Smart Magnet Technology to ensure sufficient Magnetic Adhesion.	
Supplied In Metal Carry Case with Cutter Guard & Safety Strap.	

Magnetic Drilling Machines

FOR A QUICK COMPARISON OF THE FULL RANGE PLEASE VIEW THE MAGNETIC DRILLING MACHINE SELECTION CHART ON PAGE 8



Slugger USA101

Extra Heavy Duty Compact Machine



The USA101 is a lightweight, robust performer built to last and is ideal for everyday use. Accepts Slugger cutters up to 35mm diameter and 52mm depth of cut. Powerful motor with cast aluminum housing. Through spindle coolant system with a unique coolant bottle that attaches firmly to the machine with a magnet, and can be easily removed and attached to the workpiece, allowing coolant feed whilst drilling in vertical positions. Handles can be easily changed from left to right hand operation.

*13mm twist drill bit capacity using the optional chuck & adaptor.

Optional Accessories & Consumables



Drill Chuck - pg11



Slugger Cutters - pg12

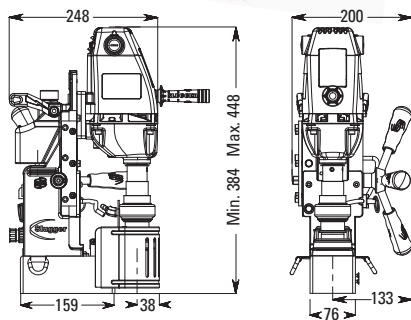

Slugger Magforce

Revolutionary Ultra Compact Constant Working Height Machine



The ultra compact design & hole capacity of 40mm x 52mm, allows the Magforce to be utilised in areas not possible with any other machine. Featuring a 285mm constant working height and weighing only 12kg, the Magforce is perfect for drilling vertical, horizontal or upside down in extremely tight spots. Left or right hand operation. Internal Coolant / Positive Slug Ejection. 1200watt high torque motor.

*12mm twist drill capacity using Weldon shank twist drill bits.



Optional Accessories & Consumables



Weldon Shank Twist Drills - pg16



Slugger Cutters - pg12

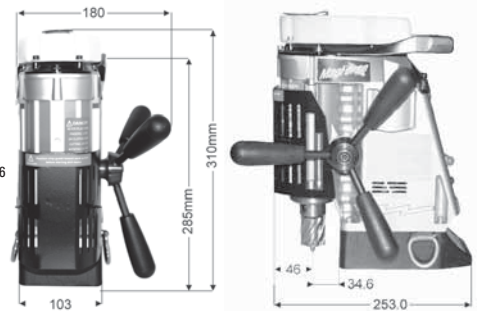

Part Number	MFV1
Capacity (Diameter)	40mm
Capacity (Depth)	52mm
Motor Power	1200Watt
Input Power	1435Watt Single Phase 240V
Speed	395rpm
Weight	12.0kg
Magnetic Dead Lift	8000N-m on 25mm Steel Plate
Height (min / max)	285mm without fluid tank 310mm with fluid tank
Incorporated Through Spindle Coolant System.	
Smart Magnet Technology with warning light for insufficient Magnetic Adhesion.	
Supplied In Moulded Carry Case with Cutter Guard & Safety Strap.	



Part Number	USA101
Capacity (Diameter)	35mm
Capacity (Depth)	52mm
Motor Power	1380Watt
Input Power	1575Watt Single Phase 240V
Speed	450rpm
Weight	13.15kg
Magnetic Dead Lift	6580N-m on 25mm Steel Plate
Height (min / max)	384mm / 448mm
Incorporated Through Spindle Coolant System.	
Smart Magnet Technology with warning light for insufficient Magnetic Adhesion.	
Supplied In Moulded Carry Case with Cutter Guard & Safety Strap.	

Magnetic Drilling Machines

FOR A QUICK COMPARISON OF THE FULL RANGE PLEASE VIEW THE MAGNETIC DRILLING MACHINE SELECTION CHART ON PAGE 8



Slugger Max 2x2 Heavy Duty #2 Morse Taper Machine



Versatility is the hallmark of this machine. Holes up to 52mm diameter by 52mm depth can be produced quickly and efficiently using Slugger cutters, and with the No 2 Morse Taper it is just at home with a Drill Chuck & Arbor or Taper Shank Drills and Reamers up to 23mm. Featuring a Heavy Duty 2 speed gear box and side mounted coolant system. This machine is perfectly suited to engineering workshops & maintenance facilities, where its versatility is most valuable.

Optional Accessories & Consumables



Drill Chuck - pg11



Slugger Cutters - pg12



Taper Shank Drills pg17

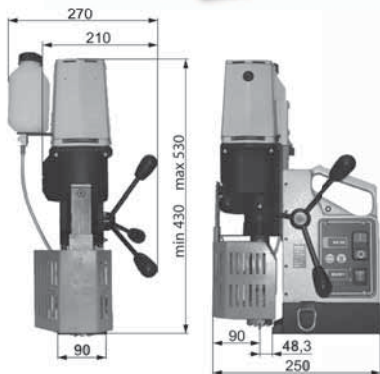

Slugger USA5000

Heavy Duty Workhorse,
Powerful & Robust



Powerful & Rugged 1400 watt motor with 2 speed gearbox & high density dual coil magnet providing optimum cutting performance. Holes up to 60mm diameter by 75mm depth can be produced quickly and efficiently. Coolant tank housed within machine frame for protection. Coolant level easily visible. Easy & precise adjustment of slides by single screw on Gib Bar. Perfect for Steel Fabrication shops requiring a heavy duty workhorse drill, Powerful & robust.

*19mm twist drill bit capacity using the optional chuck & adaptor.

Optional Accessories & Consumables



Drill Chuck - pg11



Slugger Cutters - pg12

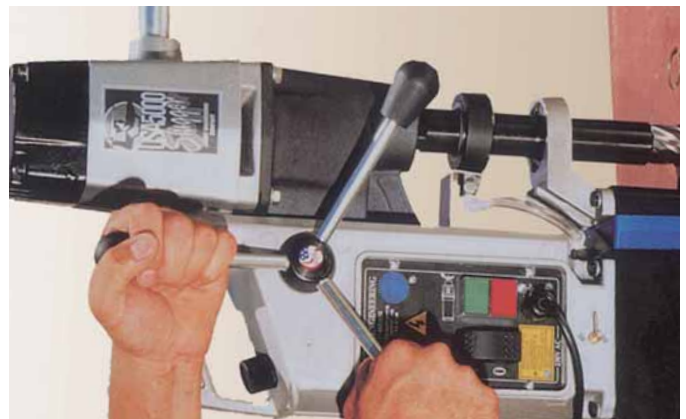
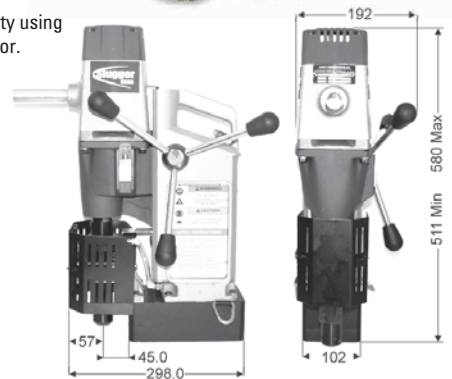

Part Number	USA5000EX
Capacity (Diameter)	60mm
Capacity (Depth)	75mm
Capacity (Twist Drills)	19mm With Optional Chuck
Motor Power	1400Watt
Input Power	1580Watt Single Phase 240V
Speed	2 Speed 270 / 520rpm
Weight	21.8kg
Magnetic Dead Lift	15000N-m on 25mm Steel Plate
Height (min / max)	511mm / 580mm
Incorporated Through Spindle Coolant System	
Smart Magnet Technology to ensure sufficient Magnetic Adhesion	
Overload warning light to advise excessive load	
Supplied In Moulded Carry Case with Cutter Guard & Safety Strap	



Part Number	SM2X2-MT2
Capacity (Diameter)	52mm
Capacity (Depth)	52mm
Capacity (Twist Drills)	#2 Morse Taper 23mm
Motor Power	1200Watt
Input Power	1380Watt Single Phase 240V
Speed	2 Speed 210 / 420rpm
Weight	17.0kg
Magnetic Dead Lift	12000N-m on 25mm Steel Plate
Height (min / max)	430mm / 530mm
Incorporated Through Spindle Coolant System	
Smart Magnet Technology to ensure sufficient Magnetic Adhesion	
Supplied In Metal Carry Case with Cutter Guard & Safety Strap	

Magnetic Drilling Machines

FOR A QUICK COMPARISON OF THE FULL RANGE PLEASE VIEW THE MAGNETIC DRILLING MACHINE SELECTION CHART ON PAGE 8

Slugger
BY JANCY ENGINEERING USA

Holemaker
QUALITY EUROPEAN MADE MAGNETIC DRILLING MACHINES

Slugger Max 3x3

#3 Morse Taper Variable Speed Machine

CUTTER CAPACITY
75 mm

32 mm
TAPER SHANK DRILLS

No 3 Morse Taper Drilling Machine Accepts Slugger Cutters, No. 3MT Drill Bits, Tapping Head & Reamers. Two speed gearbox with soft start, variable speed motor and jog reverse function, making this machine ideal for tapping. 75mm diameter x 75mm depth Slugger Cutter Capacity. Side mounted coolant system. Optional 1L pressure feed coolant bottle available.

Optional Accessories & Consumables



Drill Chuck - pg11



Slugger Cutters - pg12



Taper Shank Drills pg17



Tapping Head - pg11

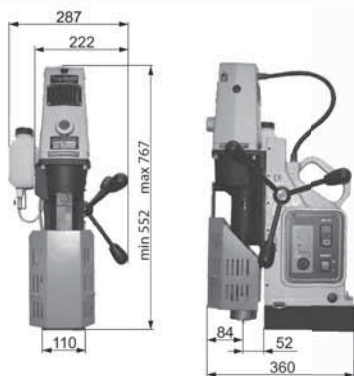

Slugger Max 4x4

#3 Morse Taper Large Capacity Machine

CUTTER CAPACITY
110 mm

32 mm
TAPER SHANK DRILLS

Retaining the largest hole-making capacity of all stocked Slugger drills, the SM4X4 is capable of producing burr-free holes up to 110mm diameter by 100mm depth. 1800w motor with 4-speed mechanical gearbox produces superb torque through gear reduction in low speeds. #3 morse taper spindle bore for use with tapered shank drills. Supplied complete with side mounted coolant system and arbor for use with 3/4" shank Slugger Cutters up to 75mm diameter by 75mm depth of cut. Optional arbor to take 1-1/4" shank cutters up to 110mm diameter by 100mm depth, 1L pressure feed coolant bottle available.



Optional Accessories & Consumables



Drill Chuck - pg11



Slugger Cutters - pg12



Taper Shank Drills pg17

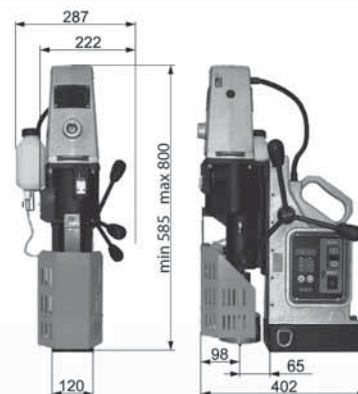

Part Number	SM3X3
Capacity (Diameter)	75mm
Capacity (Depth)	75mm
Capacity (Twist Drills)	#3 Morse Taper 32mm
Motor Power	1400Watt
Input Power	1570Watt Single Phase 240V
Speed	2 Speed Variable Gearbox with Reverse & Soft Start Function 80-160 / 160-320rpm
Weight	28.0kg
Magnetic Dead Lift	19500N-m on 25mm Steel Plate
Height (min / max)	552mm / 767mm
Incorporated Through Spindle Coolant System	
Overload warning light to advise excessive load	
Supplied In Heavy Duty Metal Carry Case	

Part Number	SM4X4
Capacity (Diameter)	110mm
Capacity (Depth)	100mm
Capacity (Twist Drills)	#3 Morse Taper 32mm
Motor Power	1800Watt
Input Power	1990Watt Single Phase 240V
Speed	4 Speed Heavy Duty Gearbox 100 / 150 / 200 / 310rpm
Weight	33.0kg
Magnetic Dead Lift	22000N-m on 25mm Steel Plate
Height (min / max)	585mm / 800mm
Incorporated Through Spindle Coolant System	
Overload warning light to advise excessive load	
Supplied In Heavy Duty Metal Carry Case	

Magnetic Drilling Machines - Pneumatic

FOR A QUICK COMPARISON OF THE FULL RANGE PLEASE VIEW THE MAGNETIC DRILLING MACHINE SELECTION CHART ON PAGE 8



Holemaker 45 Pneumatic

#2 Morse Taper Pneumatic Machine



The HMP45 is a portable pneumatic magnetic drilling machine with a cutting capacity up to 45mm diameter.

The combination of pneumatic drive and permanent magnetic base eliminate the need of electric power supply thus making this machine an ideal solution in many hazardous environments such as oil drilling platforms, mining industry, shipbuilding or petrochemical industry.



Optional Accessories & Consumables



Drill Chuck - pg11 Slugger Cutters - pg12 Taper Shank Drills pg17

Part Number	HMP45
Capacity (Diameter)	45mm
Capacity (Depth)	52mm
Capacity (Twist Drills)	#2 Morse Taper 23mm
Motor	1800watt Pneumatic, 1800L/min
Weight	17.0kg
Magnetic Dead Lift	8500N-m on 25mm Steel Plate
Stroke	120mm
Overall Dimensions: L x W x H	320 x 258 x 530
Magnet Dimensions: L x W x H	160 x 80 x 80
Incorporated Through Spindle Coolant System	
Supplied In Metal Carry Case with Cutter Guard & Safety Strap	

Holemaker 200 Pneumatic

#5 Morse Taper Large Capacity Pneumatic Machine



The HMP200 is a heavy-duty pneumatic drilling machine with milling/cutting capacity up to 200mm diameter and tapping capacity up to M48. This is a large, heavy duty magnetic drill for very special applications It can be easily assembled, positioned and used by a single operator thanks to its modular construction.

Two permanent magnetic bases, two pneumatic motors and No. 5 Morse Taper spindle make this machine one of the most powerful portable magnetic drills on the market. Optional 1L pressure feed coolant bottle available.

Optional Accessories & Consumables



Drill Chuck - pg11

Slugger Cutters - pg12

Taper Shank Drills pg17



Part Number	HMP200
Capacity (Diameter)	200mm
Capacity (Twist Drills)	45mm
Tool Holder	#5 Morse Taper
Motor	2 x 1200watt Pneumatic, 3600L/min
Gearbox	2 Speed 30rpm / 130rpm
Weight	120.0kg
Magnetic Dead Lift	2 x 15000N-m on 25mm Steel Plate
Stroke	400mm
Overall Dimensions: L x W x H	860 x 650 x 1060

Holemaker 35 Pneumatic

Low Profile Angle Drive Pneumatic Machine



The HMP35AD is a small portable pneumatic drilling machine which holes to be drilled up to 35mm diameter in places with restricted space, using standard 3/4" Weldon shank cutters. This machine is the lowest height magnetic drill currently available on the world market.

The combination of pneumatic drive and permanent magnetic base eliminate the need of electric power supply thus making this machine an ideal solution in many hazardous environments such as oil drilling platforms, mining industry, shipbuilding or petrochemical industry.

Optional Accessories & Consumables



Weldon Shank Twist Drills - pg16

Slugger Cutters - pg12



Part Number	HMP35AD
Capacity (Diameter)	35mm
Capacity (Depth)	25mm
Motor	800watt Pneumatic, 1400L/min
Weight	13.0kg
Magnetic Dead Lift	6500N-m on 25mm Steel Plate
Overall Dimensions: L x W x H	480 x 168 x 180
Incorporated Through Spindle Coolant System using remote bottle	
Supplied In Metal Carry Case with Cutter Guard & Safety Strap	

Magnetic Drilling Machines



Magnetic Drilling Machine Selection Guide

MODEL	CUTTER CAPACITY (DIAMETER X DEPTH)	DRILL BIT CAPACITY	MORSE TAPER	WEIGHT	HEIGHT (MIN/MAX)	MOTOR POWER
HOLEMAKER 30	30 x 52mm	12mm ❶	-	10.5KG	306 / 376mm	920 Watt
USA101	35 x 52mm	13mm ❷	-	13.15KG	384 / 448mm	1380 Watt
HOLEMAKER 40	40 x 52mm	13mm ❷	-	13.7KG	390 / 508mm	1100 Watt
HOLEMAKER 40GS	40 x 52mm	13mm ❷	-	13.7KG	390 / 508mm	1100 Watt
HOLEMAKER 40GR	40 x 52mm	13mm ❷	-	13.7KG	390 / 508mm	1100 Watt
HOLEMAKER 40AD	40 x 30mm	12mm ❶	-	11.1KG	181mm Constant	1080 Watt
MAGFORCE	40 x 52mm	12mm ❶	-	12.0KG	285mm Constant	1200 Watt
HOLEMAKER 50	52 x 52mm	23mm ❸	#2 Morse Taper	16.7KG	460 / 570mm	1100 Watt
HOLEMAKER 50GS	52 x 52mm	23mm ❸	#2 Morse Taper	16.7KG	460 / 570mm	1100 Watt
SLUGGER MAX 2X2	52 x 52mm	23mm ❸	#2 Morse Taper	17.0KG	430 / 530mm	1200 Watt
USA5000	60 x 75mm	19mm ❷	-	21.8KG	511 / 580mm	1400 Watt
SLUGGER MAX 3X3	75 x 75mm	32mm ❸	#3 Morse Taper	28.0KG	552 / 767mm	1400 Watt
SLUGGER MAX 4X4	110 x 100mm	32mm ❸	#3 Morse Taper	33.0KG	585 / 800mm	1800 Watt
HOLEMAKER 35AD PNEUMATIC	35 x 25mm	12mm ❶	-	13.0KG	180mm Constant	800 Watt
HOLEMAKER 45 PNEUMATIC	45 x 52mm	23mm ❸	#2 Morse Taper	17.0KG	530 / 650mm	1800 Watt
HOLEMAKER 200 PNEUMATIC	200 x 400mm	45mm ❸	#5 Morse Taper	120.0KG	1060 / 1460mm	2400 Watt

❶ USING 3/4" WELDON SHANK TWIST DRILL BITS ❷ USING OPTIONAL DRILL CHUCK ❸ USING TAPER SHANK TWIST DRILL BITS

Sluggers Display Stand

Each stand will be supplied with a large cutter display cabinet, with the following suggested popular size range of Sluggers Cutters. This can be modified where required.

Suggested Products		
SUGGESTED MACHINE STOCK	SLUGGER CUTTERS SHORT SERIES	SLUGGER CUTTERS LONG SERIES
Holemaker 30		
Holemaker 40	1 x SC1225	1 x SC1250
Holemaker 40AD	1 x SC1325	1 x SC1450
Holemaker 50	2 x SC1425	1 x SC1650
	1 x SC1625	2 x SC1850
PILOT PINS	1 x SC1725	1 x SC2050
2 x SP16001	3 x SC1825	2 x SC2250
2 x SP16002	1 x SC2025	1 x SC2450
3 x SP16003	3 x SC2225	2 x SC2650
3 x SP16004	1 x SC2425	1 x SC2850
	2 x SC2625	1 x SC3050
SPIRAL STEP DRILLS	1 x SC2825	1 x SC3250
2 x SD4-20	1 x SC3025	
2 x SD5-25	1 x SC3225	
2 x SD6-30	1 x SC3250	
2 x SD7-40.5		
CUTTING FLUIDS		
1 x SPFLUID		
1 x TAP10004E		
1 x TAP20004A		
1 x TAP10016E		

(Stock models can be varied to suit customer requirements)

The Display Stand will be provided with a stock order comprising of the above items or a similar range of Sluggers products. The Cutter Cabinet keeps stock secure while on display. It provides sufficient space to stock other Sluggers Accessories & Steelmaster Step Drills, Unika Hole Cutters, etc. The Display Stand & Cabinet remain the property of ITMS



Small Display Cabinets are also available. Please contact ITMS for further information

